

FIAMM

Industrial Batteries

FG series



FG20201

12 Volt 2.0 Ah

[На WEB-страницу товара](#)

FG20201 is a general purpose application battery. Within the FG range FIAMM offer 6V and 12V monoblocs at various amp hour capacities enable the right battery selection for each requirement. FIAMM is a Manufacturer of VRLA batteries and is supported by a dedicated sales network with market knowledge and experience of small sealed lead acid battery applications.

Features	
Nominal Voltage	12 Volt
Nominal Capacity	2.0 Ah 20 hours rate to 1.75 Vpc at 25 °C
Float charging voltage	13.50 - 13.80 V/bloc at 25 °C
Boost charge voltage	14.40 - 15.00 V/bloc at 25 °C
Float voltage compensation	-18mV/°C
Maximum charging current	0.5 A
Case	ABS with HB fiammability rate (according UL 94)
Internal resistance	88.5 mΩ in full charged condition
Weight	0.93 kg
Dimensions	L x W x H (TH): 178 x 34 x 60 (65)
Operative temperature range	-20 °C to 50 °C
Shelf life procedures	As batteries lose part of their capacity, during storage, due to self discharge. FIAMM recommends FG range of batteries can be stored for 6 months at an ambient temperature of 20 and 25 °C (see attached graph on reverse). Longer storage requires a recharge. This should be carried out in line with FIAMM recommended method; 2.4 V/cell for no longer than 24 hours at 20 °C

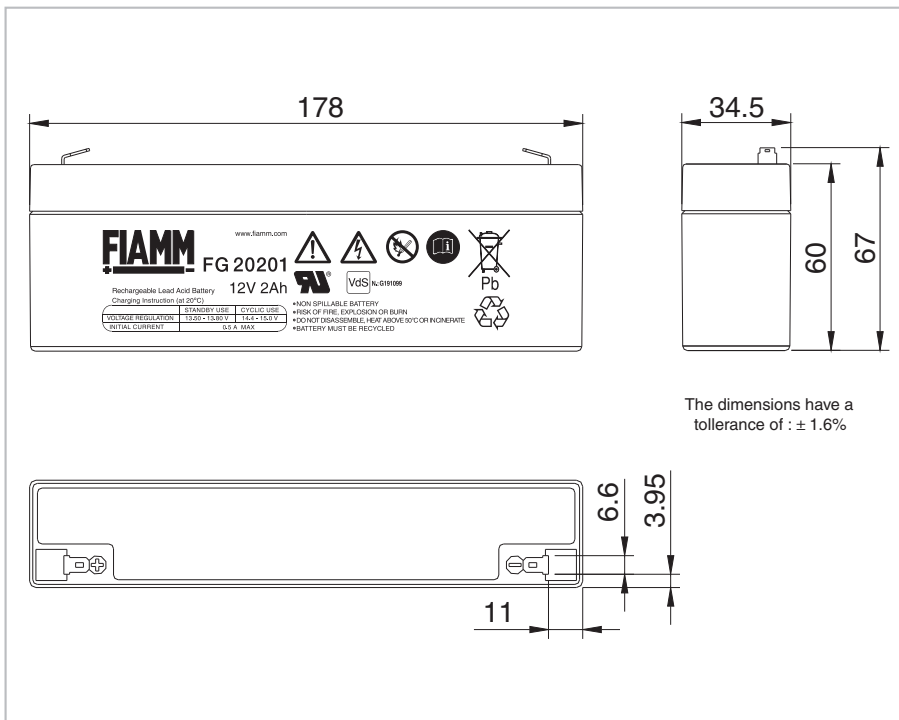

The dimensions have a tolerance of : ± 1.6%

Faston 4.8 mm

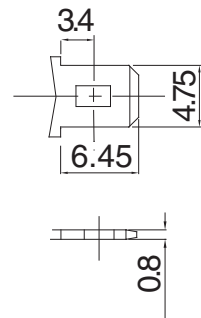

SSLA Products

[На WEB-страницу товара](#)

FG20201
12 Volt
2.0 Ah

Capacity loss during storage at various temperatures

The battery can be used without refreshing charge

Refreshing charge at 2.4 Vpc for 24 hours (at 20-25°C) must be applied as soon as possible.

Refreshing charge of 2.4 Vpc may be insufficient to recover the battery capacity. It is important to avoid this area

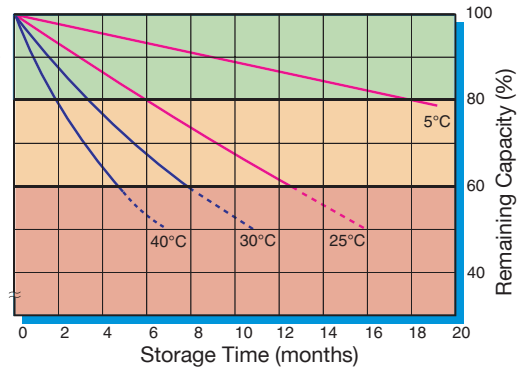

VdS N.:G191099



Battery Voltage and Charge Time for Standby Use (at 25°C)

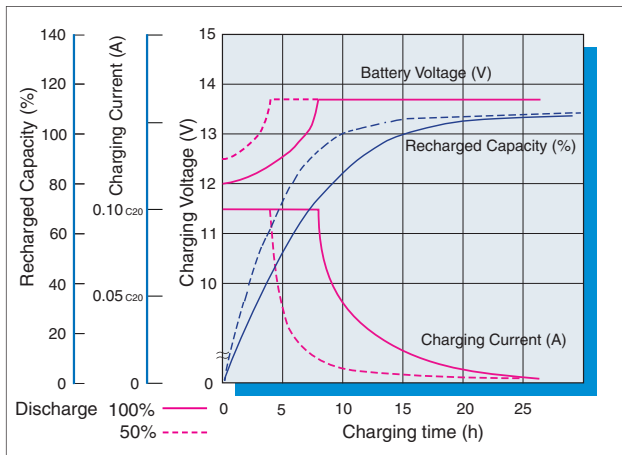

Discharge curves at different current / final voltage (at 25°C)

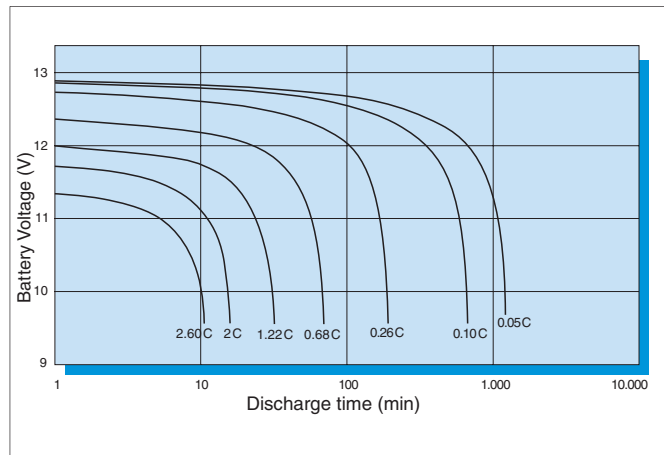

Costant Current discharge table (Amperes)

End voltage	5 min	10 min	15 min	20 min	30 min	45 min	1 hour	2 hour	3 hour	5 hour	10 hour	20 hour
9.60 V	7.45	4.93	3.68	2.97	2.16	1.59	1.27	0.72	0.53	0.34	0.19	0.10
9.90 V	7.22	4.81	3.61	2.92	2.14	1.58	1.25	0.71	0.52	0.34	0.19	0.10
10.02 V	7.04	4.76	3.57	2.90	2.12	1.56	1.24	0.70	0.52	0.33	0.19	0.10
10.20 V	6.87	4.69	3.54	2.88	2.11	1.55	1.23	0.70	0.51	0.33	0.19	0.10
10.50 V	6.60	4.60	3.47	2.81	2.08	1.52	1.21	0.68	0.51	0.33	0.18	0.10
10.80 V	6.24	4.26	3.24	2.62	1.96	1.44	1.14	0.65	0.48	0.31	0.18	0.10

Costant Power discharge table (Watts per bloc)

End voltage	5 min	10 min	15 min	20 min	30 min	45 min	1 hour	2 hour	3 hour	5 hour	10 hour	20 hour
9.60 V	74.4	50.5	38.6	31.7	23.6	17.7	14.2	8.16	6.05	3.91	2.18	0.20
9.90 V	72.5	49.7	38.0	31.3	23.4	17.7	14.1	8.09	6.03	3.90	2.18	0.20
10.02 V	70.8	49.2	37.7	31.2	23.3	17.5	14.0	8.04	6.00	3.89	2.17	0.20
10.20 V	69.2	48.6	37.5	31.0	23.2	17.3	13.9	7.97	5.94	3.87	2.17	0.20
10.50 V	66.6	47.8	36.9	30.4	22.9	17.1	13.7	7.85	5.88	3.83	2.15	0.20
10.80 V	63.4	44.4	34.7	28.5	21.7	16.3	13.0	7.58	5.57	3.65	2.08	0.19

FIAMM S.p.A.
 Industrial Batteries Business Unit
 SSLA Products
 www.fiamm.com
 e-mail: info.standby@fiamm.com



Industrial Batteries