

EV Traction Gel Industrial Battery Block

Discover[®] EV Traction GEL Batteries provide superior integrity and reliability. The maintenance-free, thick plate construction, designed to deliver excellent cycle life and very good run times at high operating voltages in tough industrial use with regular discharges, makes the EV Gel Series an excellent choice for robust industrial applications.

MECHANICAL DRAWINGS

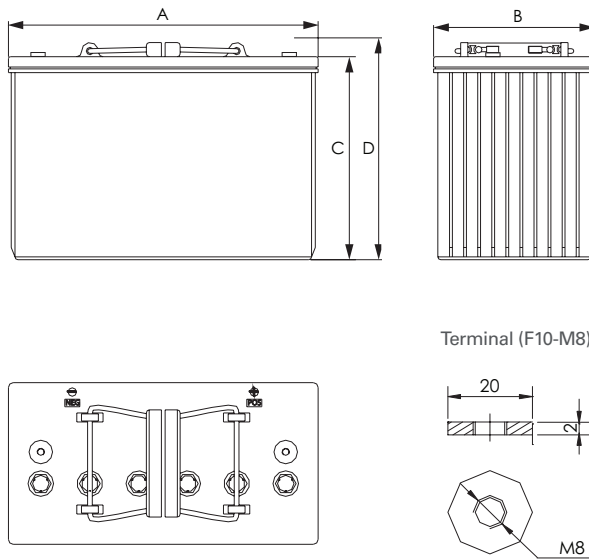

MECHANICAL SPECIFICATIONS

Industry Reference	31	
Length (A)	13.0 in	330 mm
Width (B)	6.8 in	172 mm
Height (C)	8.5 in	216 mm
Total Height (D)	9.1 in	231 mm
Weight	63.8 lbs	29 kgs
Terminal (Opt'l)*	F10-M8	
Cell(s)	6	
Electrolyte	Gel	

ELECTRICAL SPECIFICATIONS

Voltage	12 V
80% DOD Voltage Cutoff	11.8 V
Internal Resistance	5.5 mΩ
Short Circuit (20°C 68°F)	3270A
Self Discharge	Less than 3% per month (20°C 68°F)
Charge Temperature	Min: -10°C (-14°F) Max: 50°C (122°F)
Discharge Temperature***	Min: -20°C (-4°F) Max: 50°C (122°F)
Storage	Min: -20°C (-4°F) Max: 60°C (140°F)

*TERMINAL TORQUE: Please refer to our document, located in the Resources webpage (www.discoverbattery.com/resources).

**CAUTION: Extra considerations must be given to depths of discharge, operating voltages and currents when designing systems for use at maximum temperatures.

ELECTRICAL SPECIFICATIONS

Amp Hours (AH)						Minutes of Discharge				
100 HR	20 HR	10 HR	5 HR	3 HR	1 HR	@25A	@56A	@75A	@85A	@100A
105	90	85	80	66	60	180	65	38	30	22

Maximum Current	Peak (5 seconds)	Peak (10 seconds)	Continuous	Recommended Continuous
Charge	1C10Hr	0.75C10Hr	0.5C10Hr	0.3C10Hr
Discharge	2C10Hr	1.5C10Hr	1C10Hr	0.5C10Hr

BENEFITS & FEATURES

Maintenance-Free Clean & Green[®] choice of Original Equipment Manufacturers.

Traction heavy duty grid design (PbCaSn) gives consistent active material adhesion and corrosion resistance.

High impact reinforced copolymer and polypropylene cases with flat top designs.

A recognized gas recombination efficiency of greater than 99.9%.

Multiple terminal, configuration options and carrying handles available with most models.

Classified as a non-spillable battery and is not restricted for transportation by:

- Air (IATA/ICAO provision 67)
- Ground (STB, DOT-CFR-HMR49)
- Water (IMDG amendment 27)

Compatible with sensitive electronic equipment.

Comprehensive design to conserve resources, improve safety and reduce waste. 98% recyclable.

CERTIFIED QUALITY

Designed in accordance with and published in compliance with applicable BCI, IEC and BS EN standards, including:

- IEC60896-21/22
- BS EN 60254-1:2005
- AS/NZS 4029.2:2000

Discover[®] and its facilities and products are certified to multiple standards:

- ISO, UL, QS, and TUV standards
- ETTS Germany
- Euro Bat classification for
- Environmental Stewardship Standards



NOTE:

IUI with Pulse Termination algorithm uses a pulse termination criterion. As a safety precaution during the Finish phase, if the average cell voltage, or volts per cell (VPC), exceeds U2 and the charger output has been on for more than 30 seconds, the output is shut off until the vpc falls to U3. The finish phase then resumes and this "pulsing" continues until the target overcharge (108% - 112%) is reached.

NOTE 2:

Due to self-discharge characteristics of lead acid battery technologies, all batteries must be charged within 6 months of storage to prevent a possible permanent loss of capacity as a result of sulfation.

NOTE 3:

Temperature Coefficient: Adjust +/- 0.005VPC per °C (or 0.003VPC per °F) from 25°C (77°F).

TEMPERATURE EFFECTS ON CAPACITY

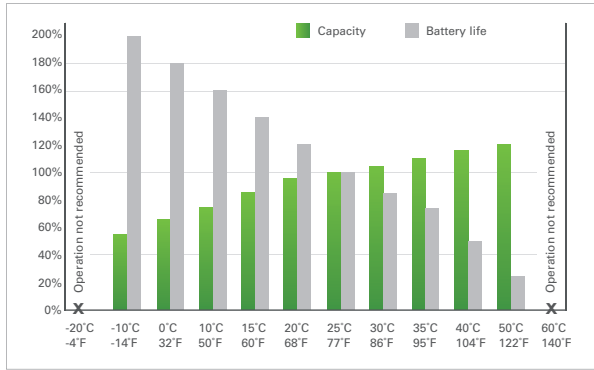

CYCLE LIFE IN RELATION TO DEPTH OF DISCHARGE (25°C)

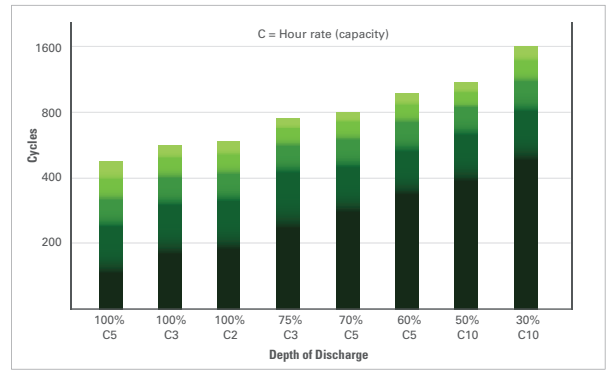

OPEN CIRCUIT VOLTAGE IN RELATION TO THE STATE OF CHARGE (20°C)

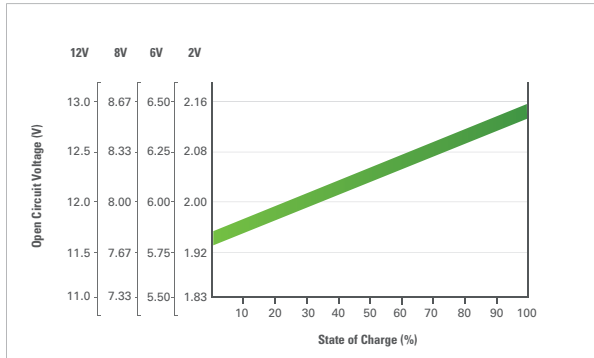

SELF-DISCHARGE CHARACTERISTICS

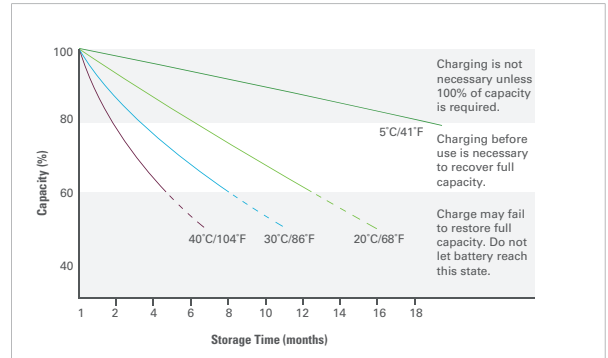

IUI WITH PULSE TERMINATION CHARGE PROFILE

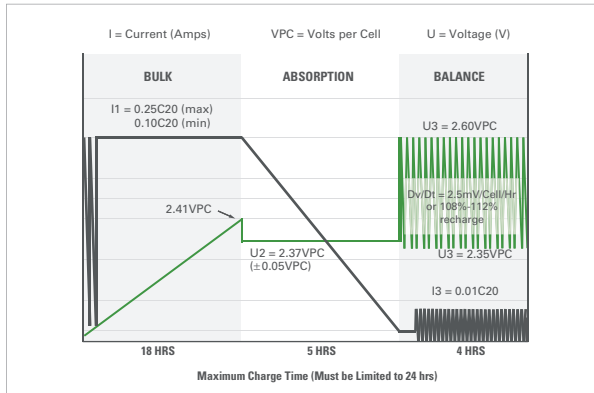

IUI CHARGE PROFILE

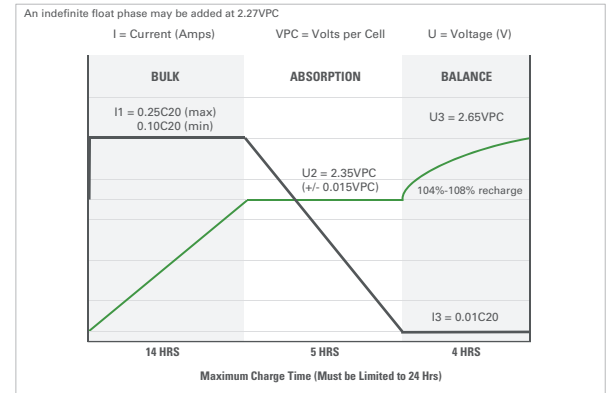

IUU CHARGE PROFILE

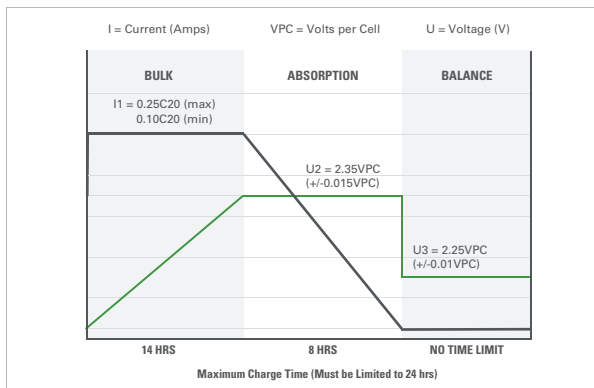

RELATION BETWEEN CHARGING, VOLTAGE AND TEMPERATURE

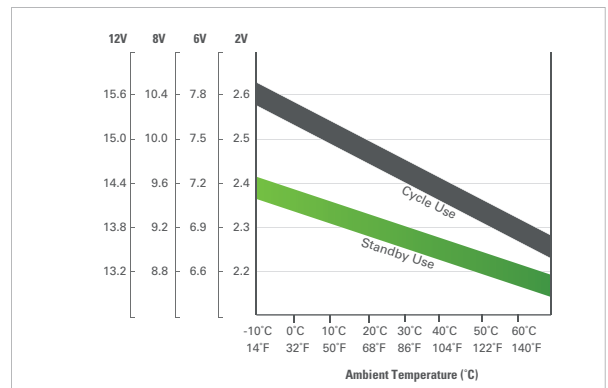

Discover® attempts to ensure the correctness of the product description and data contained herein. We reserve the right to change designs, specifications and pricing at any time without notice or obligation. It is the responsibility of the reader of this information to verify any and all information presented herein.