

PERFORMANCE SPECIFICATION FOR BATTERY TYPE FG 10301

Nominal Voltage	6 Volts
Nominal Capacity	at 20 hour rate (150 mA to 5.25 Volts), 3 Ah at 5 hour rate (0.51 mA to 5.1 Volts) 2.55 Ah at 3 hour rate (0.78 mA to 5.1 Volts) 2.34 Ah at 1 hour rate (1.82 A to 4.8 Volts) 1.82 Ah
Dimensions (mm)	Length=134, Width=34, Height=60, TH=67
Approximate weight	0.715 kg
Energy Density	66.39 Wh/l
Specific Energy	24.83 Wh/kg
Internal Resistance (Fully charged battery)	50 mΩ
Maximum discharge current in 5 seconds	30 A
Recommended charging voltage (@20°C)	floating use: 6.75-6.9 V cyclic use: 7.2-7.5 V
Thermal compensation factor	floating use: -18mV/°C cyclic use: -30mV/°C
Maximum charging current	0.75 A
Terminals	Flat lug type 4.8 mm
Torques	n.a.
Vibration Test	
- (2000 cycles/min, 2,55 mm excursion, 2 hrs)	No loss in capacity or performance
Shelf life - % of nominal capacity at 20°C	1 Month 97% 3 months 91% 6 months 83%
Storage temperature	-20°C to 40°C
Operative temperature range	Charge 0°C to 40°C Discharge -20°C to 50°C
Case material	Acrylonitrile-Butadiene-Styrene Standard Case: according to UL-94 HB Also available: according to UL-94 VO
Life expectancy (Stand-by use)	3 to 5 years according to Eurobat standards

Discharge Characteristics 20 °C (68 °C)

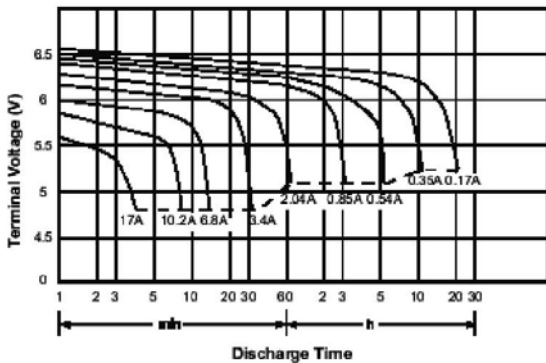

Discharge Current vs Time

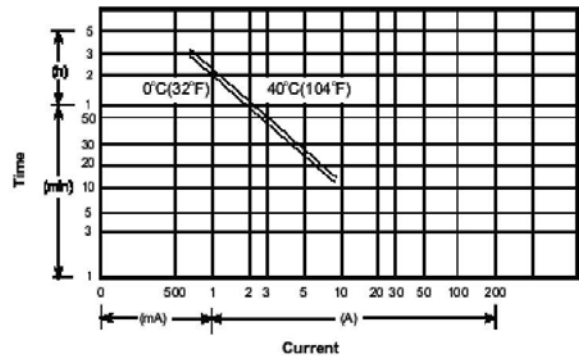

Dimensions mm (inch)

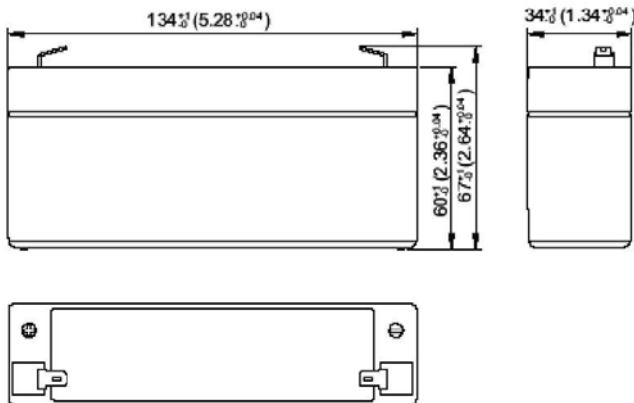

Terminal type (mm)

