

FG28009

[На WEB-страницу товара](#)

FIAMM

FIAMM Sealed Power

FG series

FG28009 is a general purpose application battery. Within the FG range Fiamm offer 6V and 12V monoblocs at various amp hour capacities enable the right battery selection for each requirement. FIAMM Sealed Power is a Manufacturer of VRLA batteries; and is supported by a dedicated sales network with market knowledge and experience of small sealed lead acid battery applications.

**12 Volt
80 Ah**



Features

| | |
|-----------------------------|---|
| Nominal Voltage | 12 Volt |
| Nominal Capacity | 80 Ah 20 hours rate to 1.75 Vpc at 25 °C |
| Float charging voltage | 13.50 - 13.80 V/bloc at 25 °C |
| Boost charge voltage | 14.40 - 15.00 V/bloc at 25 °C |
| Float voltage compensation | -18mV/°C |
| Maximum charging current | 20 A |
| Case | ABS with HB flammability rate (according UL 94) |
| Internal resistance | 4.5 mΩ in full charged condition |
| Weight | 27.20 kg |
| Dimensions | L x W x H (TH): 260 x 168 x 208 (213) |
| Operative temperature range | -20 °C to 50 °C |
| Shelf life procedures | As batteries lose part of their capacity, during storage, due to self discharge. Fiamm Sealed Power recommends FG range of batteries can be stored for 6 months at an ambient temperature of 20 and 25 °C (see attached graph on reverse). Longer storage requires a recharge. This should be carried out in line with Fiamm Sealed Power recommended method; 2.4 V/cell for no longer than 24 hours at 20 °C |

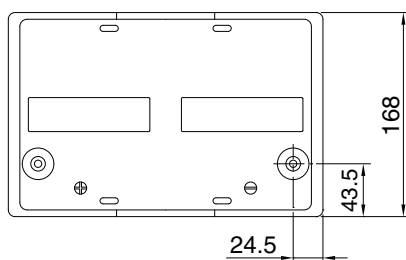
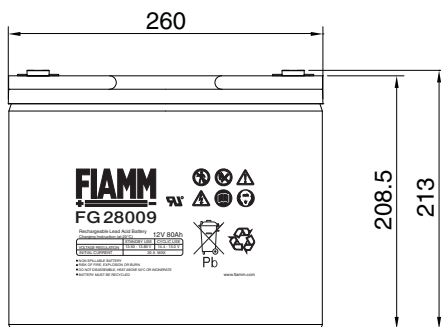

The dimensions have a tolerance of : ± 1%

Threaded inserted M8

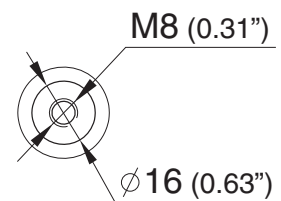

Capacity loss during storage at various temperatures

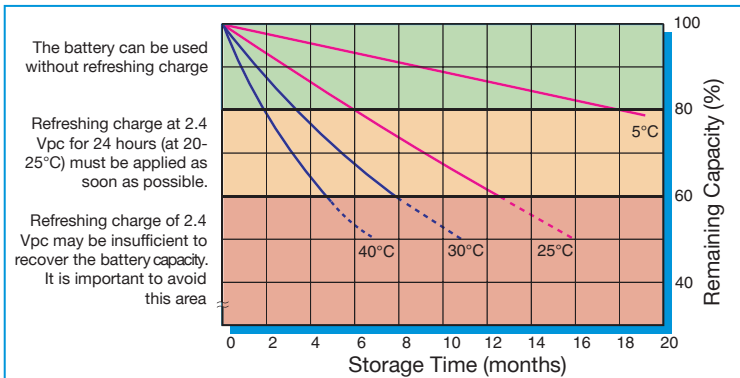

Battery Voltage and Charge Time for Standby Use (at 25°C)

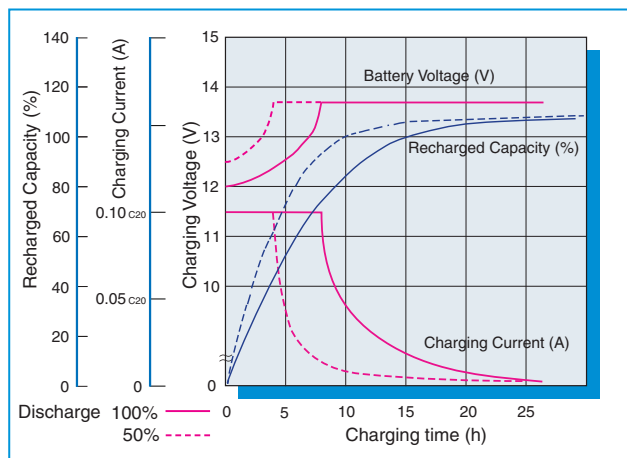

Discharge curves at different current / final voltage (at 25°C)

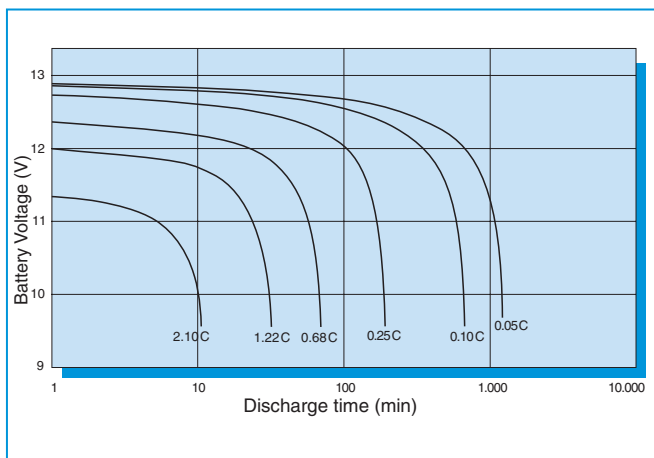

Costant Current discharge table (Amperes)

| end voltage | 5 min | 10 min | 15 min | 20 min | 30 min | 45 min | 1 hour | 2 hour | 3 hour | 5 hour | 10 hour | 20 hour |
|-------------|-------|--------|--------|--------|--------|--------|--------|--------|--------|--------|---------|---------|
| 9,60 V | 258 | 187 | 151 | 125 | 92,8 | 66,9 | 52,5 | 29,1 | 20,6 | 13,5 | 7,63 | 4,08 |
| 9,90 V | 247 | 181 | 148 | 122 | 90,9 | 65,8 | 51,7 | 28,7 | 20,4 | 13,4 | 7,58 | 4,07 |
| 10,02 V | 239 | 177 | 145 | 120 | 89,9 | 65,1 | 51,3 | 28,5 | 20,3 | 13,3 | 7,55 | 4,07 |
| 10,20 V | 232 | 174 | 141 | 118 | 88,8 | 64,4 | 50,9 | 28,3 | 20,1 | 13,2 | 7,52 | 4,06 |
| 10,50 V | 216 | 164 | 134 | 113 | 86,1 | 62,9 | 50,0 | 28,0 | 19,8 | 13,1 | 7,43 | 4,04 |
| 10,80 V | 198 | 152 | 126 | 108 | 82,9 | 61,0 | 48,6 | 27,4 | 19,4 | 12,8 | 7,30 | 3,90 |

Costant Power discharge table (Watts per bloc)

| end voltage | 5 min | 10 min | 15 min | 20 min | 30 min | 45 min | 1 hour | 2 hour | 3 hour | 5 hour | 10 hour | 20 hour |
|-------------|-------|--------|--------|--------|--------|--------|--------|--------|--------|--------|---------|---------|
| 9,60 V | 2661 | 1975 | 1617 | 1341 | 1009 | 734 | 580 | 325 | 233 | 153 | 87,4 | 47,0 |
| 9,90 V | 2595 | 1938 | 1607 | 1326 | 1000 | 729 | 577 | 324 | 231 | 153 | 87,0 | 47,0 |
| 10,02 V | 2537 | 1917 | 1581 | 1317 | 995 | 726 | 575 | 323 | 231 | 152 | 86,9 | 47,0 |
| 10,20 V | 2480 | 1895 | 1554 | 1307 | 990 | 723 | 574 | 322 | 230 | 152 | 86,7 | 46,9 |
| 10,50 V | 2357 | 1816 | 1497 | 1265 | 972 | 714 | 569 | 321 | 229 | 152 | 86,1 | 46,9 |
| 10,80 V | 2206 | 1711 | 1435 | 1227 | 951 | 702 | 561 | 318 | 226 | 149 | 85,5 | 45,7 |