

Промышленные аккумуляторы

Sonnenschein A400

Аккумуляторы с желеобразным электролитом (технология dryfit)

»Оптимальное соотношение
«цена-качество»«



Sonnenschein A400

Аккумуляторы с желеобразным электролитом (технология dryfit)

Аккумуляторы Sonnenschein A400 изготовлены по технологии dryfit (электролит загущен до желеобразного состояния). Использование данной технологии гарантирует высокую надежность аккумуляторов, что доказано успешным опытом их эксплуатации по всему миру. Большой модельный ряд позволяет выбрать необходимый тип аккумулятора для любых областей применения.

Преимущества:

- > **Технология dryfit** - высокая надежность
- > **Низкое тепловыделение** – простота размещения
- > **Прочность конструкции** – устойчивость к неблагоприятным внешним воздействиям
- > **Устойчивость к глубокому разряду** – возможность работы в режиме длительного разряда



Технические характеристики:

- > Номинальная емкость 5,5 – 180 Ач C₁₀
- > Длительный срок хранения в сочетании с большим сроком эксплуатации
- > Намазные пластины на основе толстой решетки из высококачественного сплава свинца с кальцием, что обеспечивает повышенную устойчивость к коррозии и стабильность характеристик
- > Очень низкое газовыделение благодаря процессу внутренней рекомбинации газов
- > Расчетный срок службы более 12 лет
- > Срок хранения без подзаряда (при 20°C) до 2 лет благодаря очень низкому саморазряду
- > Разработаны в соответствии со стандартом МЭК 60896-21/22 (ГОСТ Р МЭК 60896-21-2013)
- > Безопасная транспортировка аккумуляторов, отсутствие ограничений для транспортировки железнодорожным, автомобильным, морским и воздушным транспортом
- > Изготовлено в Европе на предприятиях, сертифицированных на соответствие стандарту ISO 9001



Срок службы более 12 лет



Номинальная емкость 5,5 – 180 Ач



Моноблоки



Плоские намазные пластины



Подлежат вторичной переработке



Свинцово-кислотные аккумуляторы с регулирующим клапаном

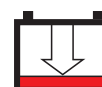

Устойчивы к глубокому разряду



Необслуживаемые (не требуют долива воды)

Sonnenschein A400

Технические характеристики

Технические характеристики

Тип	Номер по каталогу	Номинальное напряжение, В	Номинальная емкость C ₁₀ 1,80 В/эл 20°C Ач	Максимальная нагрузка А	Макс. длина (l) мм	Макс. ширина (b/w) мм	Высота (h1) без контактов мм	Высота (h2) с контактами мм	Вес, кг	Внутреннее сопротивление, мОм	Ток короткого замыкания, А	Тип вывода
A406/165 A	NGA4060165HSOCA	6	165	770	246	192	254	275	28.0	2.10	2800	A-Terminal
A406/165 F10	NGA4060165HSOFA	6	165	770	246	192	254	282	28.5	2.10	2800	F-M10
A412/5.5 SR	NGA41205D5HSORA	12	5.50	80.0	152	65.5	94.5	98.4	2.50	138	93.0	SR-6.3
A412/8.5 SR	NGA41208D5HSORA	12	8.50	80.0	152	98.0	94.5	98.4	3.60	86.0	150	SR-6.3
A412/12 SR	NGA4120012HSORA	12	12.0	100	181	76	152	157	5.60	47.0	260	SR-6.3
A412/20 G5	NGA4120020HSOBA	12	20.0	200	167	176	126	126	9.00	25.0	460	G-M5
A412/32 G6	NGA4120032HSOBA	12	32.0	400	210	175	175	175	13.6	15.0	784	G-M6
A412/32 F10	NGA4120032HSOFA	12	32.0	400	210	175	175	181	14.1	15.0	784	F-M10
A412/50 A	NGA4120050HSOCA	12	50.0	440	278	175	190	190	18.5	10.0	1220	A-Terminal
A412/50 F10	NGA4120050HSOFA	12	50.0	440	278	175	190	196	19.0	10.0	1220	F-M10
A412/50 G6	NGA4120050HSOBA	12	50.0	440	278	175	190	190	18.5	10.0	1220	G-M6
A412/65 F10	NGA4120065HSOFA	12	65.0	440	353	175	190	196	23.5	9.00	1414	F-M10
A412/65 G6	NGA4120065HSOBA	12	65.0	440	353	175	190	190	23.0	9.00	1414	G-M6
A412/85 F10	NGA4120085HSOFB	12	85.0	770	244	204	250	276	32.0	8.00	1472	F-M10
A412/90 A	NGA4120090HSOCA	12	90.0	770	284	267	208	230	33.0	7.00	1733	A-Terminal
A412/90 F10	NGA4120090HSOFA	12	90.0	770	284	267	208	237	33.5	7.00	1733	F-M10
A412/100 A	NGA4120100HSOCA	12	100	770	513	189	195	223	36.5	6.90	1777	A-Terminal
A412/100 F10	NGA4120100HSOFA	12	100	770	513	189	195	223	37.0	6.90	1777	F-M10
A412/120 A	NGA4120120HSOCA	12	120	770	513	223	195	223	45.0	5.70	2118	A-Terminal
A412/120 F10	NGA4120120HSOFA	12	120	770	513	223	195	223	45.5	5.70	2118	F-M10
A412/180 A	NGA4120180HSOCA	12	180	770	518	274	216	238	64.0	3.80	3227	A-Terminal
A412/180 F10	NGA4120180HSOFA	12	180	770	518	274	216	244	64.5	3.80	3227	F-M10

Корпус, тип вывода и момент затяжки резьбовых соединений

- > **Корпус:**
- 5,5 – 12 Ач – Акрилбутадиенстирол (ABS)
 - 20 – 180 Ач – Полипропилен (PP)

- > **Сертификация:** сертификат соответствия ГОСТ Р МЭК 60896-2-99



5 Nm



6 Nm



8 Nm



17 Nm

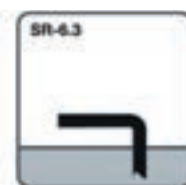

Sonnenschein A400

Чертежи

**A406/165 A
(A406/165 F10)***

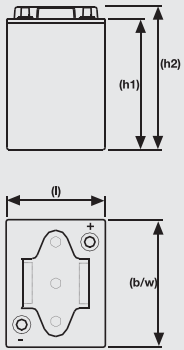

A412/5.5 SR

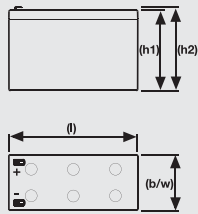

A412/8.5 SR

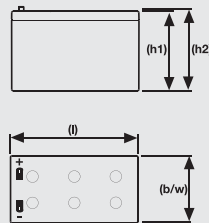

A412/12 SR

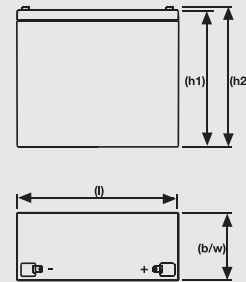

A412/20 G5

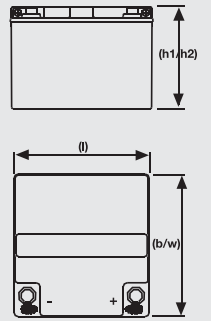

**A412/32 F10
(A412/32 G6)***

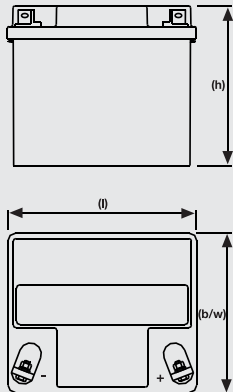

**A412/50 A
(A412/50 G6,
A412/50 F10)***

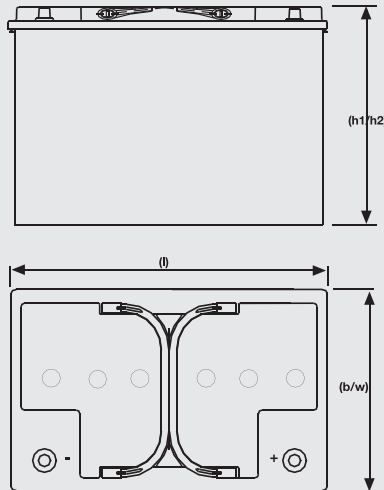

**A412/65 F10
(A412/65 G6)***

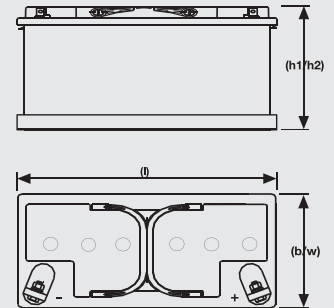

Не в масштабе!

* Размеры также верны для двух типов выводов

Sonnenschein A400

Чертежи

A412/85 F10

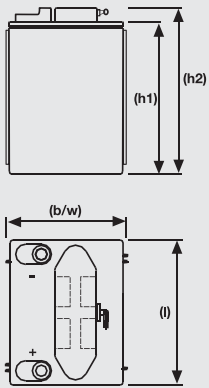

**A412/90 A
(A412/90 F10)***

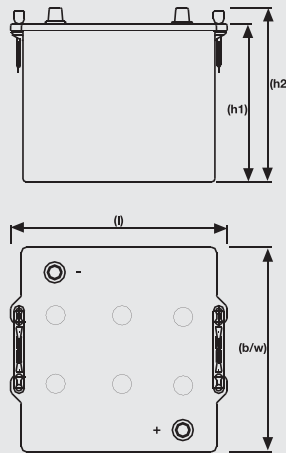

**A412/100 A
(A412/100 F10)***

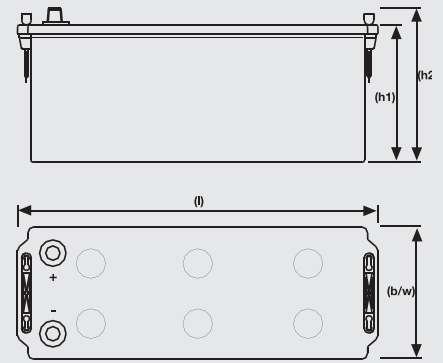

**A412/120 A
(A412/120 F10)***

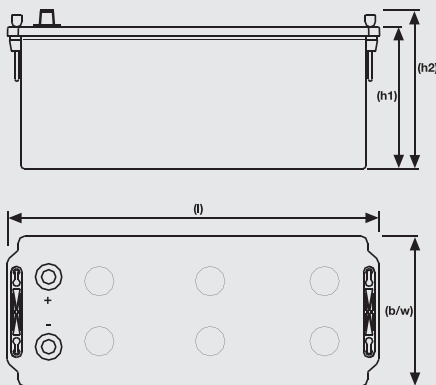

**A412/180 A
(A412/180 F10)***

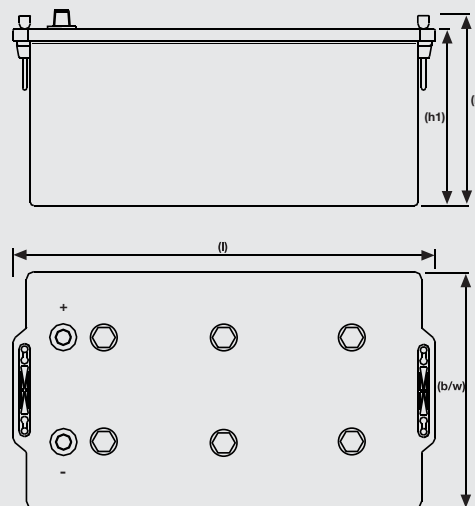

Не в масштабе!

* Размеры также верны для других типов выводов

Sonnenschein A400

Разряд постоянным током

Ток разряда (А) до напряжения 1,85 В/эл при 20°C

Тип	Номер по каталогу	5 мин	10 мин	15 мин	20 мин	30 мин	45 мин	1 ч	2 ч	3 ч	4 ч	5 ч	8 ч	10 ч
A406/165A	NGA4060165HSOCA	196	163	143	131	115	98,0	82,0	53,0	41,0	32,4	27,0	18,1	15,9
A412/5.5SR	NGA41205D5HSORA	9,94	8,34	6,97	5,96	4,85	3,76	3,00	2,00	1,44	1,14	0,96	0,64	0,53
A412/8.5SR	NGA41208D5HSORA	15,0	12,0	10,0	8,0	6,90	5,30	4,30	2,83	2,07	1,66	1,39	0,96	0,82
A412/12SR	NGA4120012HSORA	18,0	15,0	12,0	11,0	9,00	7,00	5,50	3,34	2,50	2,04	1,74	1,24	1,12
A412/20G5	NGA4120020HSOBA	33,0	25,0	22,0	20,0	17,0	14,0	11,0	6,00	4,71	3,76	3,16	2,13	1,85
A412/32G6	NGA4120032HSOBA	53,0	43,0	36,0	32,0	28,0	21,0	17,0	11,0	8,11	6,45	5,44	3,68	3,03
A412/50A	NGA4120050HSOCA	81,0	68,0	57,0	51,0	42,0	34,0	28,0	18,0	12,8	10,1	8,51	5,71	4,80
A412/65G6	NGA4120065HSOBA	102	77,0	63,0	56,0	48,0	42,0	36,0	22,0	15,9	12,8	10,8	7,31	6,20
A412/85F10	NGA4120085HSOBF	121	103	89,0	80,0	71,0	55,0	45,0	29,0	21,3	16,9	14,1	9,60	8,20
A412/90A	NGA4120090HSOCA	136	117	100	89,0	71,0	55,0	46,0	30,0	22,8	17,6	14,8	10,4	8,90
A412/100A	NGA4120100HSOCA	144	124	105	93,0	72,0	56,0	46,0	31,0	23,5	17,9	15,2	10,7	9,6
A412/120A	NGA4120120HSOCA	175	138	120	108	95,0	78,0	61,0	37,0	27,5	22,2	18,9	12,9	11,3
A412/180A	NGA412018HSOCA	240	193	170	155	130	103	84,0	59,0	42,6	34,0	28,6	19,1	16,5

Ток разряда (А) до напряжения 1,80 В/эл при 20°C

Тип	Номер по каталогу	5 мин	10 мин	15 мин	20 мин	30 мин	45 мин	1 ч	2 ч	3 ч	4 ч	5 ч	8 ч	10 ч
A406/165A	NGA4060165HSOCA	243	211	180	158	132	109,0	88,0	56,0	43,0	33,9	28,2	18,8	16,5
A412/5.5SR	NGA41205D5HSORA	11,2	9,30	7,77	6,54	5,12	4,03	3,18	2,09	1,50	1,19	0,99	0,67	0,50
A412/8.5SR	NGA41208D5HSORA	17,0	14,0	11,0	9,00	7,38	5,65	4,51	2,93	2,13	1,70	1,43	0,99	0,80
A412/12SR	NGA4120012HSORA	21,0	18,0	14,0	12,0	10,0	8,00	6,20	3,72	2,75	2,22	1,88	1,32	1,20
A412/20G5	NGA4120020HSOBA	36,0	27,0	23,0	21,0	18,0	15,0	12,0	7,00	4,89	3,88	3,25	2,19	2,00
A412/32G6	NGA4120032HSOBA	63,0	51,0	42,0	36,0	30,0	23,00	19,0	12,0	8,60	6,80	5,70	3,90	3,20
A412/50A	NGA4120050HSOCA	97,9	81,0	66,0	57,0	46,0	37,0	29,0	19,0	13,3	10,5	8,78	5,89	5,00
A412/65G6	NGA4120065HSOBA	120	95,0	76,0	64,0	52,0	45,0	39,0	23,0	16,7	13,3	11,2	7,58	6,50
A412/85F10	NGA4120085HSOBF	147	125	105	91,0	75,0	60,0	49,0	31,0	22,3	17,5	14,6	9,95	8,50
A412/90A	NGA4120090HSOCA	165	142	117	100	79,0	61,0	50,0	32,0	23,4	18,3	15,4	10,8	9,00
A412/100A	NGA4120100HSOCA	176	150	125	104,0	81,0	62,0	50,0	32,0	24,1	18,7	15,8	11,2	10,0
A412/120A	NGA4120120HSOCA	201	155	133	119	102,0	85,0	67,0	39,0	28,7	23,0	19,4	13,1	12,0
A412/180A	NGA412018HSOCA	290	235	194	171	144	112	90,0	62,0	44,6	35,5	29,7	19,8	18,0

Ток разряда (А) до напряжения 1,75 В/эл при 20°C

Тип	Номер по каталогу	5 мин	10 мин	15 мин	20 мин	30 мин	45 мин	1 ч	2 ч	3 ч	4 ч	5 ч	8 ч	10 ч
A406/165A	NGA4060165HSOCA	290	246	210	180	143	115	92,0	58,0	43,7	34,4	28,5	19,1	16,6
A412/5.5SR	NGA41205D5HSORA	12,9	9,78	8,22	6,92	5,34	4,17	3,29	2,15	1,54	1,22	1,01	0,68	0,50
A412/8.5SR	NGA41208D5HSORA	19,0	15,0	12,0	10,00	7,54	5,82	4,62	2,98	2,16	1,73	1,45	1,00	0,80
A412/12SR	NGA4120012HSORA	24,0	20,0	16,0	13,0	10,0	8,00	6,62	3,92	2,87	2,31	1,95	1,36	1,20
A412/20G5	NGA4120020HSOBA	45,0	34,0	27,0	23,0	18,0	15,0	12,0	7,00	5,00	3,90	3,30	2,20	2,00
A412/32G6	NGA4120032HSOBA	73,0	57,0	46,0	39,0	31,0	24,00	19,0	12,0	8,78	6,94	5,78	3,93	3,23
A412/50A	NGA4120050HSOCA	109	90,0	73,0	61,0	48,0	38,0	30,0	19,0	13,5	10,6	8,88	5,95	5,00
A412/65G6	NGA4120065HSOBA	134	107	84,0	70,0	56,0	48,0	41,0	24,0	17,0	13,6	11,4	7,67	6,50
A412/85F10	NGA4120085HSOBF	170	140	118	100,0	79,0	63,0	51,0	32,0	22,7	17,9	14,9	10,00	8,50
A412/90A	NGA4120090HSOCA	186	154	128	108	84,0	64,0	52,0	33,0	24,0	18,7	15,7	10,9	9,00
A412/100A	NGA4120100HSOCA	194	160	134	112,0	86,0	65,0	52,0	33,0	24,8	19,2	16,2	11,4	10,0
A412/120A	NGA4120120HSOCA	233	174	145	127	106,0	88,0	69,0	40,0	29,1	23,2	19,5	13,2	12,0
A412/180A	NGA412018HSOCA	328	266	216	185	152	117	94,0	63,0	45,5	36,1	30,1	20,1	18,0

Sonnenschein A400

Разряд постоянным током

Ток разряда (А) до напряжения 1,70 В/эл при 20°C

Тип	Номер по каталогу	5 мин	10 мин	15 мин	20 мин	30 мин	45 мин	1 ч	2 ч	3 ч	4 ч	5 ч	8 ч	10 ч
A406/165A	NGA4060165HSOCA	332	273	233	198	152	119	93,9	58,0	43,9	34,6	28,7	19,1	16,6
A412/5.5SR	NGA41205D5HSORA	14,2	10,2	8,58	7,17	5,48	4,26	3,35	2,18	1,56	1,23	1,02	0,70	0,50
A412/8.5SR	NGA41208D5HSORA	21,0	15,0	12,0	10,00	7,63	5,92	4,68	3,00	2,18	1,74	1,46	1,00	0,80
A412/12SR	NGA4120012HSORA	28,0	21,0	16,0	13,0	10,0	8,00	6,77	3,99	2,91	2,33	1,96	1,40	1,20
A412/20G5	NGA4120020HSOBA	51,0	37,9	29,0	24,0	19,0	15,0	12,0	7,00	5,00	3,96	3,30	2,20	2,00
A412/32G6	NGA4120032HSOBA	84,0	61,0	50,0	42,0	32,0	25,00	20,0	12,0	8,90	7,00	5,80	3,90	3,20
A412/50A	NGA4120050HSOCA	122	94,0	77,0	64,0	49,0	39,0	31,0	18,9	13,5	10,7	8,92	6,00	5,00
A412/65G6	NGA4120065HSOBA	148	111	89,0	73,0	57,0	49,0	41,0	24,0	17,2	13,7	11,4	7,70	6,50
A412/85F10	NGA4120085HSOBF	192	151	127	106	82,0	64,0	52,0	32,0	22,8	17,9	14,8	10,0	8,50
A412/90A	NGA4120090HSOCA	206	164	137	113	87,0	66,0	53,0	33,0	24,3	18,9	16,2	11,0	9,00
A412/100A	NGA4120100HSOCA	213	171	41	117,0	89,0	67,0	53,0	34,0	25,1	19,3	17,0	11,4	10,0
A412/120A	NGA4120120HSOCA	280	200	160	136	109	90,0	70,0	40,0	29,3	23,3	19,5	13,2	12,0
A412/180A	NGA412018HSOCA	366	287	234	199	156	120	95,0	64,0	45,9	36,3	30,3	20,2	18,0

Ток разряда (А) до напряжения 1,65 В/эл при 20°C

Тип	Номер по каталогу	5 мин	10 мин	15 мин	20 мин	30 мин	45 мин	1 ч	2 ч	3 ч	4 ч	5 ч	8 ч	10 ч
A406/165A	NGA4060165HSOCA	389	301	248	210	157	121	95,0	59,0	43,9	34,6	28,7	19,1	16,6
A412/5.5SR	NGA41205D5HSORA	15,5	10,6	8,71	7,30	5,57	4,34	3,40	2,19	1,56	1,23	1,00	0,70	0,50
A412/8.5SR	NGA41208D5HSORA	23,0	16,0	12,0	10,0	7,70	5,98	4,73	3,01	2,19	1,74	1,50	1,00	0,80
A412/12SR	NGA4120012HSORA	30,0	22,0	17,0	14,0	11,0	9,00	6,80	4,00	2,92	2,34	2,00	1,40	1,20
A412/20G5	NGA4120020HSOBA	56,0	40,0	31,0	25,0	19,0	15,0	12,0	7,00	5,01	3,97	3,30	2,20	2,00
A412/32G6	NGA4120032HSOBA	94,0	65,0	52,0	43,0	33,0	25,00	20,0	12,0	8,90	7,01	5,80	3,90	3,20
A412/50A	NGA4120050HSOCA	133	98,0	79,0	66,0	50,0	39,0	31,0	19,0	13,6	10,7	8,90	6,00	5,00
A412/65G6	NGA4120065HSOBA	161	114	91,0	75,0	57,0	49,0	42,0	24,0	17,3	13,7	11,5	7,70	6,50
A412/85F10	NGA4120085HSOBF	210	159	134	110	84,0	65,0	52,0	32,0	22,8	17,9	14,9	10,0	8,50
A412/90A	NGA4120090HSOCA	225	172	142	116	88,0	67,0	53,0	33,0	24,4	18,9	16,3	11,0	9,00
A412/100A	NGA4120100HSOCA	232	178	146	120	90,0	68,0	54,0	34,0	25,3	19,5	17,0	11,4	10,0
A412/120A	NGA4120120HSOCA	311	217	169	142	111	91,0	71,0	41,0	29,4	23,4	19,6	13,2	12,0
A412/180A	NGA412018HSOCA	399	305	250	212	159	122	96,0	63,9	46,0	36,4	30,4	20,2	18,0

Ток разряда (А) до напряжения 1,60 В/эл при 20°C

Тип	Номер по каталогу	5 мин	10 мин	15 мин	20 мин	30 мин	45 мин	1 ч	2 ч	3 ч	4 ч	5 ч	8 ч	10 ч
A406/165A	NGA4060165HSOCA	422	318	256	215	160	122	96,0	59,0	44,0	34,6	28,7	19,1	16,6
A412/5.5SR	NGA41205D5HSORA	16,1	10,9	8,88	7,45	5,64	4,37	3,42	2,19	1,56	1,23	1,00	0,70	0,50
A412/8.5SR	NGA41208D5HSORA	24,0	16,0	13,0	10,0	7,79	6,03	4,76	3,02	2,19	1,74	1,50	1,00	0,80
A412/12SR	NGA4120012HSORA	33,0	23,0	17,0	14,0	11,0	9,00	6,82	4,01	2,92	2,34	2,00	1,40	1,20
A412/20G5	NGA4120020HSOBA	60,0	42,0	31,0	26,0	19,0	15,0	12,0	7,00	5,02	3,97	3,30	2,20	2,00
A412/32G6	NGA4120032HSOBA	101	68,0	54,0	44,0	33,0	25,00	20,0	12,0	8,91	7,01	5,80	3,90	3,20
A412/50A	NGA4120050HSOCA	144	101	81,0	67,0	51,0	40,0	31,0	19,0	13,6	10,7	8,90	6,00	5,00
A412/65G6	NGA4120065HSOBA	170	116	92,0	76,0	58,0	49,0	42,0	23,9	17,3	13,7	11,5	7,70	6,50
A412/85F10	NGA4120085HSOBF	229	166	137	113	85,0	66,0	52,0	32,0	22,8	17,9	14,9	10,0	8,50
A412/90A	NGA4120090HSOCA	245	177	145	118	89,0	68,0	54,0	34,0	24,5	19,0	16,3	11,0	9,00
A412/100A	NGA4120100HSOCA	253	183	149	121	91,0	69,0	54,0	34,0	25,4	19,5	17,0	11,4	10,0
A412/120A	NGA4120120HSOCA	333	228	175	146	112	91,0	71,0	41,0	29,4	23,4	19,6	13,2	12,0
A412/180A	NGA412018HSOCA	439	322	258	217	162	123	96,0	64,0	46,0	36,4	30,4	20,2	18,0

Sonnenschein A400

Разряд постоянной мощностью

Мощность разряда (Вт/блок) до напряжения 1,85 В/эл при 20°C

Тип	Номер по каталогу	2 мин	3 мин	5 мин	7 мин	10 мин	15 мин	20 мин	30 мин	45 мин	1 ч	2 ч	3 ч
A406/165A	NGA4060165HSOCA	1310	1262	1171	1096	1005	875	797	689	543	458	293	222
A412/5.5SR	NGA41205D5HSORA	153	140	120	106	95,0	79,5	68,7	58,4	44,3	36,4	22,0	16,0
A412/8.5SR	NGA41208D5HSORA	216	200	176	159	141	117	101	84,4	64,8	53,7	31,0	22,0
A412/12SR	NGA4120012HSORA	251	239	219	203	184	156	140	114	89,4	74,8	38,0	29,0
A412/20G5	NGA4120020HSOBA	437	414	378	348	302	257	229	195	151	125	71,0	51,0
A412/32G6	NGA4120032HSOBA	679	633	580	532	483	413	366	303	233	194	128	92,0
A412/50A	NGA4120050HSOCA	1149	1074	1002	949	876	785	699	590	458	375	193	139
A412/65G6	NGA4120065HSOBA	1440	1341	1221	1137	1025	867	759	635	481	395	239	175
A412/85F10	NGA4120085HSOBF	1311	1275	1230	1158	1071	952	865	761	591	494	324	233
A412/90A	NGA4120090HSOCA	1685	1619	1493	1374	1243	1080	987	827	646	542	332	246
A412/100A	NGA4120100HSOCA	1873	1792	1625	1482	1329	1144	1047	860	674	567	335	252
A412/120A	NGA4120120HSOCA	2417	2253	1963	1773	1574	1384	1272	1109	914	745	410	300
A412/180A	NGA412018HSOCA	3474	3323	3112	2959	2679	2284	2010	1562	1214	1015	632	467

Мощность разряда (Вт/блок) до напряжения 1,80 В/эл при 20°C

Тип	Номер по каталогу	2 мин	3 мин	5 мин	7 мин	10 мин	15 мин	20 мин	30 мин	45 мин	1 ч	2 ч	3 ч
A406/165A	NGA4060165HSOCA	1622	1548	1414	1315	1184	1020	900	768	595	494	318	241
A412/5.5SR	NGA41205D5HSORA	174	160	140	122	106	87,6	74,4	62,1	47,1	38,4	24,0	17,0
A412/8.5SR	NGA41208D5HSORA	246	232	203	188	156	129	110	90,4	68,5	56,3	33,0	24,0
A412/12SR	NGA4120012HSORA	314	291	258	235	208	177	153	125	95,8	79,2	42,0	31,0
A412/20G5	NGA4120020HSOBA	565	520	467	421	358	291	251	208	159	131	77,0	55,0
A412/32G6	NGA4120032HSOBA	826	764	677	621	562	467	403	332	252	207	135	98,0
A412/50A	NGA4120050HSOCA	1385	1269	1134	1040	969	862	769	625	492	400	210	151
A412/65G6	NGA4120065HSOBA	1701	1601	1429	1295	1158	976	834	690	516	420	260	190
A412/85F10	NGA4120085HSOBF	1667	1572	1463	1375	1276	1082	960	803	637	526	352	253
A412/90A	NGA4120090HSOCA	1939	1848	1706	1554	1394	1184	1061	890	691	573	360	267
A412/100A	NGA4120100HSOCA	2076	1986	1828	1644	1454	1235	1112	934	719	597	364	274
A412/120A	NGA4120120HSOCA	2958	2667	2286	2026	1769	1496	1346	1146	971	802	446	326
A412/180A	NGA412018HSOCA	4109	3998	3559	3336	3012	2594	2241	1756	1339	1104	687	507

Мощность разряда (Вт/блок) до напряжения 1,75 В/эл при 20°C

Тип	Номер по каталогу	2 мин	3 мин	5 мин	7 мин	10 мин	15 мин	20 мин	30 мин	45 мин	1 ч	2 ч	3 ч
A406/165A	NGA4060165HSOCA	1850	1780	1628	1493	1356	1146	980	796	622	512	337	247
A412/5.5SR	NGA41205D5HSORA	196	178	155	134	114	93,1	78,3	63,4	48,8	39,6	24,0	17,0
A412/8.5SR	NGA41208D5HSORA	278	258	226	198	171	138	116	93,6	70,5	57,6	34,0	25,0
A412/12SR	NGA4120012HSORA	354	331	295	262	233	192	163	131	99,3	81,0	45,0	33,0
A412/20G5	NGA4120020HSOBA	658	595	518	467	397	315	267	213	164	134	77,0	56,0
A412/32G6	NGA4120032HSOBA	959	881	776	691	612	508	431	350	262	214	139	99,0
A412/50A	NGA4120050HSOCA	1591	1480	1293	1148	1032	923	819	653	510	413	215	152
A412/65G6	NGA4120065HSOBA	1968	1830	1620	1447	1267	1054	886	714	533	431	270	193
A412/85F10	NGA4120085HSOBF	1908	1826	1674	1532	1421	1200	1033	838	664	544	360	256
A412/90A	NGA4120090HSOCA	2301	2184	1984	1796	1564	1298	1128	927	716	590	375	272
A412/100A	NGA4120100HSOCA	2948	2364	2139	1928	1635	1348	1175	972	742	612	383	280
A412/120A	NGA4120120HSOCA	3453	3084	2593	2262	1940	1609	1387	1176	997	829	460	329
A412/180A	NGA412018HSOCA	4555	4307	3950	3659	3316	2821	2399	1876	1413	1156	695	515

Sonnenschein A400

Разряд постоянной мощностью

Мощность разряда (Вт/блок) до напряжения 1,70 В/эл при 20°C

Тип	Номер по каталогу	2 мин	3 мин	5 мин	7 мин	10 мин	15 мин	20 мин	30 мин	45 мин	1 ч	2 ч	3 ч
A406/165A	NGA4060165HSOCA	1993	1913	1778	1636	1455	1230	1036	814	637	521	339	247
A412/5.5SR	NGA41205D5HSORA	219	193	162	147	119	96,6	80,7	64,2	49,8	40,3	24,0	18,0
A412/8.5SR	NGA41208D5HSORA	306	282	246	212	177	143	119	95,2	71,5	58,3	34,0	25,0
A412/12SR	NGA4120012HSORA	394	365	323	285	247	202	170	134	101	82,4	45,0	33,0
A412/20G5	NGA4120020HSOBA	741	657	555	494	423	330	277	216	166	135	78,0	56,0
A412/32G6	NGA4120032HSOBA	1064	990	861	751	638	536	450	338	269	218	139	100,0
A412/50A	NGA4120050HSOCA	1734	1584	1406	1234	1079	956	848	668	519	419	216	153
A412/65G6	NGA4120065HSOBA	2191	2008	1762	1570	1322	1099	916	722	541	436	270	194
A412/85F10	NGA4120085HSOBF	2076	1987	1837	1671	1510	1275	1084	862	678	554	362	256
A412/90A	NGA4120090HSOCA	2553	2398	2176	1950	1669	1367	1171	945	727	597	375	273
A412/100A	NGA4120100HSOCA	2792	2604	2346	2090	1749	1413	1215	986	751	619	385	282
A412/120A	NGA4120120HSOCA	3821	3501	2938	2497	2089	1699	1441	1195	1008	840	460	330
A412/180A	NGA412018HSOCA	4990	4742	4298	3929	3477	2975	2502	1944	1455	1184	697	517

Мощность разряда (Вт/блок) до напряжения 1,65 В/эл при 20°C

Тип	Номер по каталогу	2 мин	3 мин	5 мин	7 мин	10 мин	15 мин	20 мин	30 мин	45 мин	1 ч	2 ч	3 ч
A406/165A	NGA4060165HSOCA	2162	2055	1879	1734	1526	1278	1067	827	642	525	341	248
A412/5.5SR	NGA41205D5HSORA	235	208	169	149	122	98,8	82,3	64,7	50,5	40,7	24,0	18,0
A412/8.5SR	NGA41208D5HSORA	331	305	258	222	183	146	121	96,1	72,0	58,7	34,0	25,0
A412/12SR	NGA4120012HSORA	436	399	348	304	255	209	174	135	101	82,9	45,0	33,0
A412/20G5	NGA4120020HSOBA	799	700	583	511	438	338	282	218	167	136	79,0	56,0
A412/32G6	NGA4120032HSOBA	1161	1068	916	801	666	554	461	361	272	221	139	100,0
A412/50A	NGA4120050HSOCA	1931	1747	1480	1308	1120	991	865	677	523	421	217	153
A412/65G6	NGA4120065HSOBA	2419	2213	1847	1657	1371	1124	932	726	544	439	271	195
A412/85F10	NGA4120085HSOBF	2255	2139	1963	1770	1569	1325	1116	876	665	559	364	257
A412/90A	NGA4120090HSOCA	2823	2597	2304	2067	1743	1414	1200	954	732	601	376	274
A412/100A	NGA4120100HSOCA	3108	2887	2475	2216	1831	1459	1241	993	755	622	387	283
A412/120A	NGA4120120HSOCA	4111	3798	3170	2682	2193	1756	1474	1205	1012	844	460	331
A412/180A	NGA412018HSOCA	5419	5099	4628	4162	3588	3073	2565	1978	1475	1198	700	518

Мощность разряда (Вт/блок) до напряжения 1,60 В/эл при 20°C

Тип	Номер по каталогу	2 мин	3 мин	5 мин	7 мин	10 мин	15 мин	20 мин	30 мин	45 мин	1 ч	2 ч	3 ч
A406/165A	NGA4060165HSOCA	2351	2202	1987	1828	1588	1307	1085	835	646	527	342	249
A412/5.5SR	NGA41205D5HSORA	248	220	175	153	125	100,0	83,3	65,0	51,0	41,1	24,0	18,0
A412/8.5SR	NGA41208D5HSORA	354	324	267	228	186	147	122	96,7	72,3	58,9	34,0	25,0
A412/12SR	NGA4120012HSORA	474	423	358	317	262	212	176	136	102	83,1	45,0	33,0
A412/20G5	NGA4120020HSOBA	874	760	610	521	446	343	285	219	167	136	80,0	56,0
A412/32G6	NGA4120032HSOBA	1245	1143	952	835	687	565	469	366	276	223	140	101,0
A412/50A	NGA4120050HSOCA	2216	1989	1583	1362	1151	1000	875	681	526	423	218	154
A412/65G6	NGA4120065HSOBA	2603	2401	1961	1712	1399	1137	939	728	546	440	272	196
A412/85F10	NGA4120085HSOBF	2431	2280	2058	1867	1608	1357	1136	884	689	561	365	257
A412/90A	NGA4120090HSOCA	3046	2754	2397	2156	1792	1444	1217	960	735	603	377	275
A412/100A	NGA4120100HSOCA	3354	2992	2567	2301	1884	1487	1257	998	758	624	388	284
A412/120A	NGA4120120HSOCA	4296	3942	3330	2779	2260	1791	1494	1210	1014	846	460	332
A412/180A	NGA412018HSOCA	5825	5395	4832	4360	3701	3130	2599	1993	1484	1203	702	519

